

Phase-conjugate Fizeau interferometer

Daniel J. Gauthier and Robert W. Boyd

The Institute of Optics, University of Rochester, Rochester, New York 14627

Robert K. Jungquist, Jerold B. Lisson, and Laurie Lyon Voci

Eastman Kodak Company, Rochester, New York 14653

Received September 27, 1988; accepted January 6, 1989

We describe a phase-conjugate interferometer that consists of a partially transmitting conventional mirror placed in front of and in close proximity to a phase-conjugate mirror. The interferometer is self-referencing, compact, and insensitive to environmental disturbances, provides twice the sensitivity of conventional (nonphase-conjugate) interferometers, and produces a direct representation of an incident wave front. We have constructed such a device using internally self-pumped phase conjugation in barium titanate and have used the device to characterize the wave front produced by an aberrated optical system.

There has been much interest recently in the properties of interferometers containing phase-conjugate mirrors (PCM's). In a phase-conjugate interferometer an incident light wave is made to interfere with a wave-front-reversed (phase-conjugate) replica of itself, thereby producing an interference pattern that directly displays the wave front of the incident light. Phase-conjugate interferometry derives its unique properties from the qualitatively different nature of reflection from ordinary mirrors and from PCM's,¹ as shown schematically in Fig. 1. Phase-conjugate interferometers are self-referencing in that no additional reference wave front is used, hence they are useful for applications such as wave-front sensing.

In this Letter we describe a compact design for a real-time phase-conjugate interferometer and present results that demonstrate the use of this interferometer for the alignment and testing of optical systems. Previously described² phase-conjugate interferometers have been Michelson or Mach-Zehnder interferometers in which one of the mirrors has been replaced by a PCM. Our design is the phase-conjugate analogue of the Fizeau interferometer,³ as shown in Fig. 2. The wave front to be sampled is shown at the exit pupil of some arbitrary optical system to be tested. This wave passes through a beam splitter and then into the wave-front sensor. Part of the incident wave is reflected at the surface of a partially reflecting conventional mirror. The transmitted portion of the wave falls onto a PCM, where a wave-front-reversed replica of the incident wave front is produced. The two reflected waves travel back toward the exit pupil and are sampled by the beam splitter. The lens is used to form a real image of the conventional mirror where the interference fringes are examined. The fringes are examined in the plane of the conventional mirror because this is the plane where the two wave fronts are phase conjugates of each other. Since we are interested in examining the wave front at the exit pupil of the optical system, this exit pupil must either be imaged onto the conventional mirror or (as in our experiment and as

shown in Fig. 2) the distance between the exit pupil and the conventional mirror must be sufficiently small that negligible diffraction occurs in this distance. Figure 2 shows the conventional mirror as having a plane surface, although in practice this mirror could have any surface figure in order to null any overall curvature of the incident wave front. Note that the phase-conjugate Fizeau interferometer possesses the desirable feature of requiring only one reference surface of high optical quality.

In the particular implementation of the phase-conjugate Fizeau interferometer that we have studied experimentally the phase-conjugate wave front was produced by the process of internally self-pumped phase conjugation in a single crystal of barium titanate.⁴ In

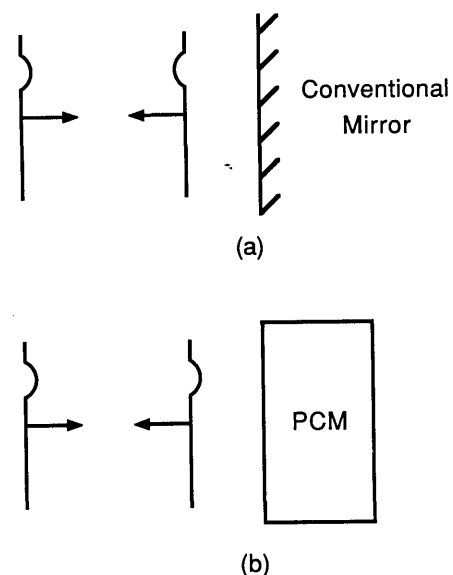

Fig. 1. Schematic representation of the wave front reflected by (a) a conventional mirror and (b) a PCM. The two reflected waves are subsequently allowed to interfere in a phase-conjugate interferometer.

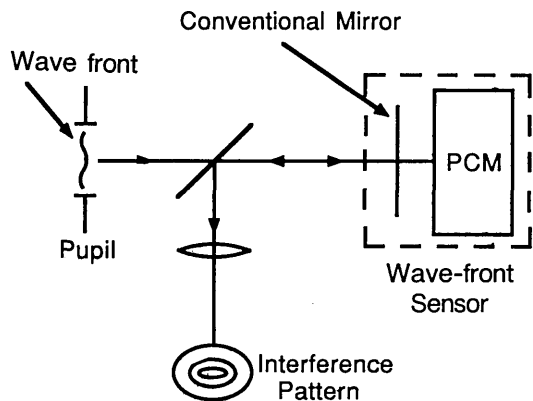

Fig. 2. The phase-conjugate Fizeau interferometer.

most of the experiments described here the conventional mirror was the flat surface of a 100-mm focal-length plano-convex lens that was used to focus the light into the barium titanate crystal, although in some of the experiments the conventional mirror was one of the surfaces of the barium titanate crystal. Illumination was provided by a single-transverse-mode and single-longitudinal-mode argon-ion laser operating at a wavelength of 515 nm and delivering approximately 50 mW of power to the barium titanate crystal. A Faraday isolator providing more than 60 dB of isolation⁵ was used to prevent feedback from the PCM into the laser, and a clean wave front was produced by passing the beam through a spatial filter.

The wave-front-sensing capabilities of the interferometer were demonstrated by placing an aberrating optical system into the incident laser beam. The optical system was a unit-magnification telescope made up

of plano-convex lenses and had 5-mm-diameter entrance and exit pupils. In some of our experiments the plane surfaces of the lenses were placed toward the infinite conjugates in order to introduce several waves of spherical aberration into the wave front. In other experiments the lenses were placed with the curved surfaces toward the infinite conjugates in order to minimize spherical aberration but tilted in order to introduce several waves of astigmatism into the laser wave front.⁶

Some of the interference patterns that we have observed experimentally are shown in Fig. 3. Figure 3(a) shows the interference pattern produced with the aberrating system removed and with the conventional mirror oriented to produce tilt fringes. The slight curvature of the fringes is due to the small amount of residual spherical aberration produced by the collimating lens of the spatial filter. Figure 3(b) shows the interference pattern produced when the telescope with the lenses positioned to produce spherical aberration was inserted into the beam. The focus of the telescope was adjusted to collimate the marginal rays, and the conventional mirror of the interferometer was oriented to produce no tilt fringes. The three dark rings indicate that approximately 1.5 waves of spherical aberration have been introduced by the telescope. For comparison, the wave front produced by the aberrating optical system was studied by using two different conventional interferometers. Figure 3(c) shows the interference pattern produced by a conventional Mach-Zehnder interferometer. Note that there are half as many fringes in this case because the aberrating wave front is being interfered with an additional plane wave front and not the wave-front-reversed replica of itself. In collecting these data we

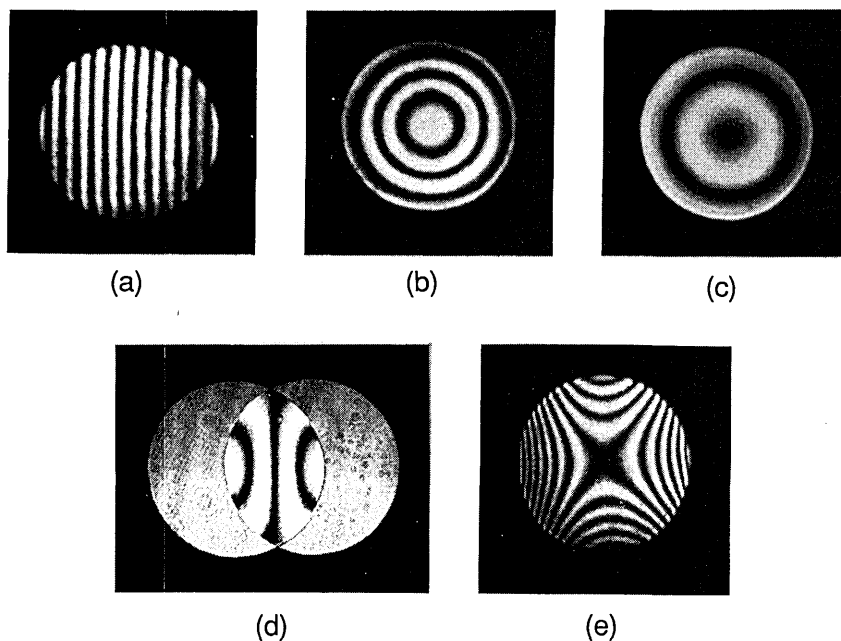

Fig. 3. Interferograms produced by the phase-conjugate Fizeau interferometer for (a) a nearly unaberrated wave front and (b) a wave front containing approximately 1.5 waves of spherical aberration. For comparison, interferograms produced by (c) a conventional Mach-Zehnder interferometer and (d) a conventional shearing interferometer are shown. The interferogram produced by the phase-conjugate Fizeau interferometer for a wave front containing two waves of astigmatism is shown in (e).

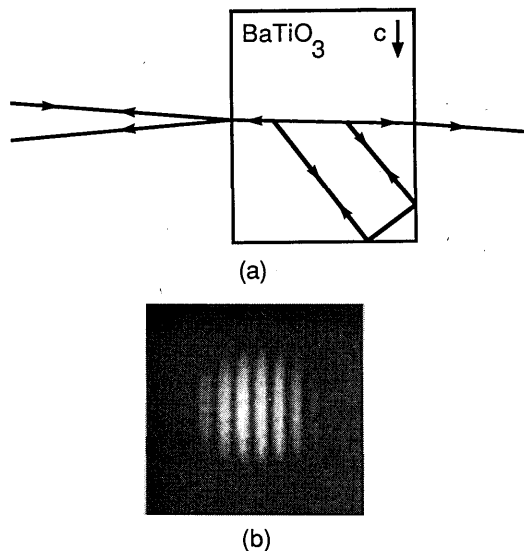

Fig. 4. (a) Single-element phase-conjugate Fizeau interferometer. (b) The interferogram produced by this device for the case of a nearly unaberrated wave front.

noticed that the interference pattern produced by the phase-conjugate Fizeau interferometer was much more stable than that produced by the Mach-Zehnder interferometer. It is well known that common-path interferometers produce extremely stable interference patterns. The phase-conjugate Fizeau is a common-path interferometer because any aberrations encountered in that portion of the optical path between the conventional mirror and the PCM are entirely canceled in the return pass owing to the nature of the phase-conjugation process. In Fig. 3(d) we show the interference pattern produced by a shearing interferometer, which is a conventional common-path interferometer. It is impossible to determine the wave front from a single interference pattern of this sort because a shearing interferometer determines the derivative of the wave front only in the direction of the shear. The interference pattern produced by the phase-conjugate Fizeau interferometer for a different aberration is shown in Fig. 3(e). In this case the lenses of the telescope were tilted to produce approximately two waves of astigmatism, and the focus of the telescope was adjusted to produce the best possible degree of collimation for the aberrated beam.

To demonstrate that phase-conjugate Fizeau interferometers can be extremely compact, a single-element interferometer was designed and constructed. In this design a barium titanate crystal⁷ of dimensions 12 mm × 12 mm × 10 mm was used as both the PCM and the conventional mirror. Figure 4(a) shows a ray of light incident upon this interferometer. Part of the incident light is reflected from the front surface of the crystal and subsequently interferes with the light generated inside the crystal by the self-pumped phase-conjugation process. As noted by earlier researchers,⁸ the intensity of the surface reflection decreased with increasing phase-conjugate reflectivity owing to the tendency of PCM's to suppress reflected waves⁹; how-

ever, this effect was not sufficiently pronounced to degrade the quality of the interference pattern produced by the single-element interferometer. Figure 4(b) shows the interference pattern formed for the case in which the aberrating telescope has been removed and in which the conventional mirror (crystal face) is oriented to produce tilt fringes. The fringes produced in this case are of comparable quality with those shown in Fig. 3(a), which was produced by an interferometer in which the conventional mirror was a high-quality optical flat. This result shows that barium titanate can be fabricated with an adequate surface figure to be useful in phase-conjugate interferometry.

In conclusion, we have demonstrated a phase-conjugate Fizeau interferometer that offers several advantages for wave-front sensing over other interferometers. It is an extremely compact common-path interferometer and consequently is less sensitive to environmental effects than other types of phase-conjugate interferometers; it is self-referencing and provides a twofold improvement in sensitivity compared with conventional interferometers, which are properties common to all phase-conjugate interferometers; and it produces interference patterns that are easily interpretable in that they display the incident wave front and not its spatial derivative, unlike the case of shearing interferometers. Further improvements in sensitivity could be possible through use of ac interferometric techniques that can be implemented by modulating the phase of the conjugate wave by applying a modulated voltage to the crystal.¹⁰

This research was supported by the sponsors of the New York State Center for Advanced Optical Technology, Rochester, New York.

Robert K. Jungquist and Laurie Lyon Voci are also with the New York State Center for Advanced Optical Technology, The Institute of Optics, University of Rochester, Rochester, New York 14627.

References

1. R. W. Boyd, T. M. Habashy, A. A. Jacobs, L. Mandel, M. Nieto-Vesperinas, W. R. Tompkin, and E. Wolf, *Opt. Lett.* **12**, 42 (1987).
2. F. A. Hopf, *J. Opt. Soc. Am.* **70**, 1320 (1980); I. Bar-Joseph, A. Hardy, Y. Katzir, and Y. Silberberg, *Opt. Lett.* **6**, 414 (1981); J. Feinberg, *Opt. Lett.* **8**, 569 (1983); W. L. Howes, *Appl. Opt.* **25**, 473, 3167 (1986).
3. H. Fizeau, *Ann. Chim. Phys.* **66**, 429 (1862).
4. J. Feinberg, *Opt. Lett.* **7**, 486 (1982); K. R. MacDonald and J. Feinberg, *J. Opt. Soc. Am.* **73**, 548 (1983).
5. D. J. Gauthier, P. Narum, and R. W. Boyd, *Opt. Lett.* **11**, 623 (1986).
6. R. Kingslake, *Lens Design Fundamentals* (Academic, New York, 1978); D. Malacara, ed., *Optical Shop Testing* (Wiley, New York, 1978).
7. Manufactured by Sanders Associates, 95 Canal Street, Nashua, N.H.
8. I. Lindsay and J. C. Dainty, *Opt. Commun.* **59**, 405 (1986).
9. A. T. Friberg and P. D. Drummond, *J. Opt. Soc. Am.* **73**, 1216 (1983).
10. D. M. Pepper, *Appl. Phys. Lett.* **49**, 1001 (1986).